



RTP-W50WC  
電熱水瓶  
Thermo Pot



僅適用於家庭使用  
For household use only

## 使用說明書 OPERATION MANUAL

- 在使用本產品前，請仔細閱讀本說明書，閱讀後小心收藏，以備日後查閱。  
Please read the operation manual carefully before using. Keep it in a safe place for future reference.
- 本說明書中的圖示可能與實物有不同的地方，僅供參考。  
Some figures in this manual may not match with the real object, just for reference only.

非常感謝您選購樂信牌電熱水瓶，使用前請先詳細閱讀本說明書，並保存以備日後參考。

## 目錄

1. 安全注意事項
2. 保養及日常清潔
3. 產品規格
4. 產品說明
5. 使用方法
6. 故障排除
7. 特別聲明
8. 售後服務



## 1. 安全注意事項









使用本產品時，必須遵守下列安全措施：

下圖表示由於錯誤操作而引起不同程度的危險等級。

 <b>警告</b> 此標誌表示可能造成傷亡。	 <b>注意</b> 此標誌表示可能造成傷害或財物損失。
---	--

以下不同標誌區分各種必須遵守的指示。

 此標誌表示禁止。	 此標誌表示必須遵守。
---	---

 <b>注意</b>	
 使用前，請仔細閱讀相關的說明。如錯誤操作，可造成傷害。	 使用前，請確定產品表面清潔乾爽，否則可能引致故障。
 為免熱水溢出，當產品盛載著熱水時，切勿傾斜或搖晃產品，或用力關閉上蓋。移動產品時，請使用提手，切勿以上蓋作手挽。	 當溫度過高時，此產品會啟動防乾燒保護功能並自動截斷電源。
 使用時，確保產品與四周保持最少10厘米的距離作散熱空間。	 切勿從水龍頭或在洗滌槽中直接加水，否則可能導致水流入機內，造成電子零件故障或發生危險。
 切勿盛載水以外的液體 (如牛奶、茶或冰塊等)。	 倒去剩水時，應先卸下上蓋 (請參考5.7拆除上蓋)。使用時，請確保上蓋已關緊。

## 注意



切勿讓剩水長期留在內膽，否則可導致內膽變色或產生異味。



使用後，必須從電源插座拔出插頭及待產品冷卻後才移動、清潔或檢查。



不可放重物在電源線上；切勿夾住、改裝、用力拉扯或扭曲電源線。



在插入或拔除插頭時，應用手握穩插頭本身，不要抓住電源線。



切勿在電源線纏結的情況下使用此產品或將電源線懸掛在桌子、櫥櫃的邊緣或讓它接觸發熱的表面，否則可能造成電源線損壞。



切勿在以下環境使用此產品：  
— 潮濕或近水的環境；  
— 被陽光直接照射或靠近熱源如焗爐、電磁爐及火源；  
— 不平穩的表面上；  
— 易燃物料或不耐熱物品附近（如枱布、窗簾及毛巾等）。

## 警告



使用前，確保電源線兩端的插頭分別插緊在產品及電源插座上，否則可能因接觸不良導致電源線過熱。



切勿與其他高功率的電器同時共用同一電源插座；或超額使用電線拖板，以防電力負荷過重而導致火災。



使用前，確保插頭已充分擦乾。



切勿讓此產品在無人看管下運作。



切勿用任何物件覆蓋產品表面或遮擋蒸氣口，以免造成變色或變形。



需時常留意水位，必須在水位低於注水指示線前注水，避免引起產品乾燒。



切勿注水超過滿水指示線，否則使用時熱水可能噴出，造成燙傷。



切勿把此產品、電源線或插頭浸入水中；或被水濺濕，以免造成觸電或火災。

## 警告



切勿讓小孩單獨使用、清潔及維修保養此產品或將其當作玩具。請將此產品及其電源線放於小孩不能觸及的地方。



切勿擅自改裝此產品或使用非生產商提供的零件進行修理，否則可造成危險及維修保養將會無效。



出水時，切勿旋轉產品，以免熱水飛濺及造成燙傷。



手濕時切勿接觸、插入或拔除插頭，否則可能構成觸電。



當水沸騰時，切勿使用出水功能或打開上蓋，否則會導致熱水飛濺或大量蒸氣噴出，可能造成燙傷。



經常檢查此產品、電源線及插頭，如有損壞，為避免危險，請立即停止使用，並聯絡信興電器服務中心有限公司安排檢查及維修。



當產品內沒有水時，切勿啟動產品，避免引起乾燒。如果產品經常出現乾燒，可能會令內膽變黃，並影響產品的功能及耐用性。



此產品只供家庭或類似環境使用，如商店內部、辦事處和其他工作環境的員工廚房區域；旅館、汽車旅館和其他住宿類型的環境。



此產品可供年齡在8歲或以上的兒童及體質、感覺或智力有障礙人士或缺乏經驗和相關知識的人士使用，但他們必須接受負責安全人士的監督或指導如何安全地使用此產品和理解所涉及的危險。



使用時或剛使用後，會有大量灼熱蒸氣由蒸氣口噴出。為避免燙傷，切勿將臉頰或手等靠近或接觸上蓋或蒸氣口；或觸碰變熱的表面如外殼。切勿觸摸使用後的發熱部份，因仍有餘熱。

## 2. 清潔及日常保養

1. 清潔前，必須先拔掉電源插頭，並待電熱水瓶冷卻後才能進行。
2. 建議每天要把剩餘熱水倒掉，否則內膽會形成水垢或產生異味。倒水前，必須拔掉電源插頭及卸下上蓋。倒水時，切勿讓水濺到面板或進入機內，用手按緊手柄及拿穩機身，才慢慢傾斜機身將剩水倒掉。

3. 切勿用水直接沖洗電熱水瓶，應用濕布擦拭機身表面。
4. 切勿使用有毒或含腐蝕性的清潔劑進行清潔。若污漬太多，可用軟布沾上稀釋的中性清潔劑擦拭機身，然後用乾淨的濕布抹淨。
5. 上蓋的保養

上蓋會因長期使用而損耗，損耗的程度會因水質和使用次數而不同。如發現上蓋損壞或有裂痕時而導致出水困難，請聯絡信興電器服務中心有限公司進行檢查或購買新上蓋更換。

### 6. 內膽的保養

在使用時，用戶可能發現內膽表面出現色點如乳白色、啡色或黑色，這是由於水中含有礦物質所引起，請定期清洗，以防止形成水垢或色點。可用海綿清洗內膽，切勿使用去污粉或金屬刷擦拭內膽，以免內膽表層受損。

如要清除水垢，可使用以下清洗方法：

- 將1-2個已切片的檸檬放入瓶內，(或以每升水加入20克檸檬酸。)
- 於內膽注入冷水至滿水指示線。
- 按**清洗**鍵後，顯示屏會顯示電源標誌及清洗標誌，產品會開始加熱至沸騰。待清洗標誌閃動，表示清洗已完成。浸泡約1小時後，把瓶內的水全部倒掉，並用海綿或軟毛刷清洗內膽，然後用水沖洗。
- 為去除剩餘的檸檬酸，可再次注水沸騰，然後把開水倒掉即可。

## 3. 產品規格

型號	RTP-W50WC
額定電壓	220-240 伏特~ 50/60 赫茲
額定功率	750-890 瓦
內膽物料	不鏽鋼
容量	5.0 升
淨重 (約)	2.1 公斤
產品尺寸 (闊 x 深 x 高)	295 x 235 x 309 毫米

# 4. 產品說明

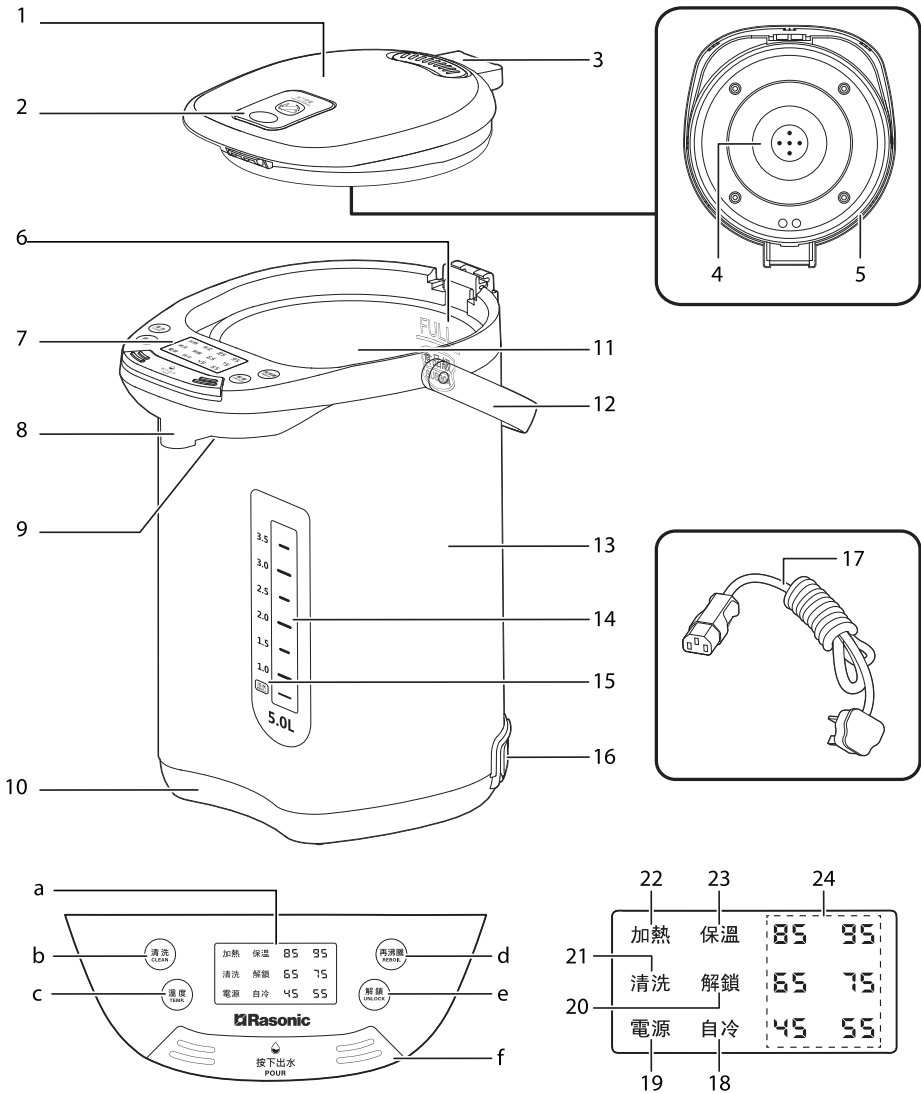

## 零件

- |          |           |
|----------|-----------|
| 1. 上蓋    | 8. 出水口    |
| 2. 開蓋拉鈕  | 9. 碰杯出水鈕  |
| 3. 蒸氣口   | 10. 旋轉底座  |
| 4. 內膽上蓋  | 11. 內膽    |
| 5. 密封環   | 12. 手柄    |
| 6. 滿水指示線 | 13. 機身    |
| 7. 控制面板  | 14. 水位顯示窗 |
| a. 液晶顯示屏 | 15. 注水指示線 |
| b. 清洗鈕   | 16. 電源插座  |
| c. 溫度鈕   | 17. 電線及插頭 |
| d. 再沸騰鈕  |           |
| e. 解鎖鈕   |           |
| f. 電動出水鈕 |           |

## 液晶顯示屏標誌

18. 自冷模式
19. 電源
20. 解鎖
21. 清洗模式
22. 加熱模式
23. 保溫模式
24. 保溫溫度設定(°C)



## 5. 使用方法

### 5.1 設置

1. 將本產品放在穩固防滑、耐熱防水的表面上。
2. 按下及拉起開蓋拉鈕(如產品上所示)，以拉開上蓋。
3. 使用水壺將室溫的水注入內膽。請確保水位超過注水指示線，但低於滿水指示線。
4. 關上上蓋，並確保上蓋扣緊。

**注意：**如上蓋未有正確扣緊，本產品將不會加熱至適當溫度。

- 於首次使用本產品前，請將水注入至滿水指示線及加熱，然後將水倒掉，以去除灰塵或異味。請使用柔軟的濕布清潔機身。

### 5.2 啟動本產品

- 將電線插入本產品背面的電源插座，再將插頭插入牆上的插座。本產品會響起「嗶」聲，顯示屏亦會亮起。
- 本產品將自動進入加熱模式，並開始將水煮沸後保溫至預設的85°C。
- 於加熱模式中，顯示屏會顯示電源標誌、加熱標誌及預設保溫溫度。
- 如本產品正在乾燒，將會停止加熱。加熱及解鎖標誌將會閃動，以作提示。如要解鎖及再次使用本產品：
  1. 從牆上的插座拔出插頭。
  2. 將水注入本產品，確保水位超過注水指示線。
  3. 將插頭插入牆上的插座。

#### **注意：**

- 於加熱時，請保持上蓋扣緊。
- 蒸氣口噴出蒸氣，或打開及關上上蓋時，請確保雙手及臉頰遠離蒸氣口及上蓋。

### 5.3 設定保溫溫度／自冷模式

- 如要設定水沸騰後的保溫溫度，可以重複按下**溫度鈕**，並選擇下列選項：95°C、85°C、75°C、65°C、55°C、45°C或自行冷卻。
- 本產品將會開始保溫，顯示屏會顯示保溫標誌。當水沸騰後，保溫功能將會啟動。在水冷卻至保溫溫度的過程中，螢幕上的溫度標誌將會閃動。當達到預設溫度後，溫度標誌將不再閃動。

**注意：**本產品的保溫功能並無時間限制。只要產品一直通電，便可持續保溫。

- 如果水溫跌至較預設的保溫溫度低5°C，在本產品將水加熱至預設溫度的過程中，顯示屏將會顯示保溫標誌及溫度。
- 如選擇自冷模式，保溫模式將會停止，螢幕會顯示自冷標誌。熱水將會逐漸冷卻至室溫。

### 5.4 使用再沸騰模式

- 在保溫模式中，可以按下**再沸騰鈕**，將水重新加熱。
- 顯示屏將會顯示加熱標誌，直至水沸騰。
- 將水重新煮開可以減少水中的氯氣，改善味道及氣味。

### 5.5 使用兒童安全鎖

- 產品設有兒童安全鎖，以防止兒童誤觸**電動出水鈕**/碰杯出水鈕從本產品中倒出熱水。(備用狀態下，兒童安全鎖為鎖定狀態)
- 按下**解鎖鈕**，可解開兒童安全鎖，顯示屏顯示解鎖標誌，表示產品已解鎖。

### 5.6 出水方式

- 如要倒水，請確保兒童安全鎖已解鎖。
- 將杯子或水壺放在出水口下方，然後按下**電動出水鈕**，或者將杯子貼在碰杯出水鈕上，便可以將水倒入杯子。如要停止倒水，可以鬆開按鈕。
- 如長時間未有使用本產品，請清空內膽，並從插座拔出電線。

### 5.7 拆除上蓋

1. 先將上蓋打開，將上蓋拉向出水口方向，再向上拉，可以拆除上蓋。

**注意：**在清空內膽時，必須拆除上蓋，以避免沾濕上蓋及電子控制面板。

2. 將水慢慢倒出，確保不會沾濕控制面板。
3. 使用柔軟的濕布清潔本產品的內殼及外殼。
4. 徹底抹乾所有零件後裝回上蓋。

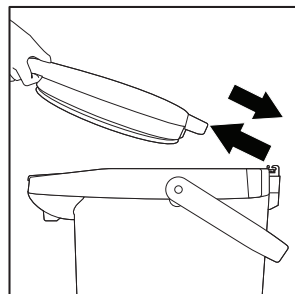
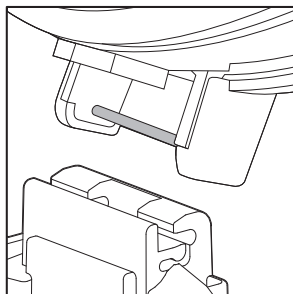
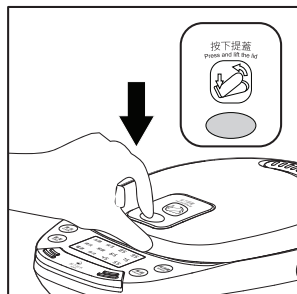

## 6. 故障排除

問題	原因	處理方法
水中有白色或閃光的物質。	這是脫落的水垢。	請按第4頁內膽的保養的方法去除水垢。
水有異味。	<ul style="list-style-type: none"> <li>• 自來水中含有消毒用氯氣，導致產生異味。</li> <li>• 電熱水瓶的封閉包裝會令使用初期有少許異味。</li> </ul>	<ul style="list-style-type: none"> <li>• 可按下“再沸騰”鍵清除氯味。</li> <li>• 隨著使用次數增加將會消失；或用檸檬片或檸檬酸放進水裏加熱，即可減退異味。</li> </ul>
出水不暢。	出水過濾網被堵塞。	請用軟毛刷清洗過濾網。
水自動流出。	注水超過滿水指示線。	減少內膽內的水量至低於滿水指示線。
不能煲水。	插頭未有徹底連接。	檢查及重新連接插頭。

如使用以上方法後仍未能解決問題，請聯絡信興電器服務中心有限公司進行檢查及維修。

## 7. 特別聲明

1. 此說明書所有內容經過核對，如有任何印刷錯誤或內容上的誤解，本公司將保留解釋權。

2. 本產品若有技術改進，會編進新版說明書中，恕不另行通知；產品外觀及規格以廠方資料為準。
3. 使用說明書的電子副本可透過電子郵件發送致客戶，如有需要，請致電信興電工工程有限公司：2861 2767。

## 8. 售後服務

信興電工工程有限公司（“本公司”）將授權信興電器服務中心有限公司（“服務中心”）（統稱“信興”）提供一年保修服務並由發票上的日期起計。超過這期間者，客戶須按服務中心的修理服務價目表繳付一切費用。

1. 信興對於任何因產品不適當地使用或任何產品之故障、損壞或停頓而引致任何人士或財產的直接或間接損失及破壞，概不負責。
2. 客戶須自行將產品送往客戶服務中心或市區內，並於產品修妥後於同一地點取回。
3. 保修卡（印在包裝盒上）只適用於香港及澳門。於修理時，客戶需出示保修卡及由香港或澳門經銷商發出的正式發票/或換購收據予技術員查閱。保修卡上之產品型號必須與機身相符，保修卡上之購買日期須與正式發票上的日期符合，方為有效。除指定保修卡外，任何商號及人士發出之保修卡，均不為信興認可。
4. 客戶不可擅自更改產品上的機身編號，如發現產品上的機身編號與保修卡所列者不符，保修卡則告無效。（如適用）
5. 除產品表面、機殼、損耗性零件及附件外，產品如發生故障，經服務中心證實乃在正常使用情況下發生者，服務中心將提供免費修理及更換零件，經更換後之任何損壞零件，將歸服務中心所有。
6. 下列項目並不包括於保修範圍內。客戶須另付所需的服務費用。（甲）修理或更換產品之附件、外接線及機殼。（乙）曾被非服務中心的技術員明顯地或不明顯地進行改裝、更改或修理的產品。（丙）曾經被不適當或疏忽使用、不正常供電或電壓不正常、意外、天災或因昆蟲、外物、液體入侵、腐蝕或外來因素而造成損壞的產品。（丁）因產品不正確安裝而影響正常之操作。
7. 如中英文版本有差異時，應以中文版為準。
8. 所有資料如有任何更改，恕不另行通知。如有任何爭議，服務中心保留最終決定權。
9. 保修卡沒有賦予或意圖賦予任何第三者因《合約（第三者權利）條例》（第623章）所列之任何利益或權利以強制執行保修卡的任何條款內容。

Thank you for purchasing Rasonic Thermo Pot. Read the operation manual carefully before using and well keep it for your future reference.



## **Table of Contents**

1. Important Safeguards
2. Cleaning, Storage and Maintenance
3. Product Specification
4. Product Description
5. Operation Instruction
6. Trouble Shooting
7. Special Avowal
8. After Sales Service



## 1. Important Safeguards



When using the appliance, please follow the below safety precautions:

The following chart indicates the degree of damage caused by wrong operation.







 <b>WARNING</b> Indicates that may cause death or serious injury.	 <b>CAUTION</b> Indicates hazards that may cause human injuries or property damages.
---	--

The following symbols can distinguish the instruction types that need to be strictly followed.

 These symbols mean prohibition.	 These symbols mean requirement that must be followed.
--	--

 <b>CAUTION</b>	
 Read all instructions carefully before use. Misuse can cause potential injury.	 Make sure the appliance surface is clean and dry before use, otherwise it may cause malfunction.

 **CAUTION**

-  To avoid hot water from spilling out, do not tilt or shake the appliance or close the lid by force when it contains hot water. When move the appliance, catch its handle instead of the bare lid.
-  The appliance will trigger the boildry protection and cut off the power automatically when the temperature is too high.
-  During operation, keep at least 10cm space at all sides of the appliance for air circulation.
-  Do not fill water directly from the tap or in a sink, otherwise water may get into the appliance, it may cause electronic parts malfunction or danger.
-  Do not contain other liquids except water (e.g. milk, tea, ice, etc.)
-  Detach the lid (refer to 5.7 Removing the lid) before pouring out the remnant water. Make sure the lid is closed tight when in use.

 **CAUTION**



Do not leave the remnant water in the inner pot for a long time, it may cause color change on the inner pot or produce bad smell.



After use, please unplug the appliance and let the appliance cool down before moving, cleaning or checking.



Do not place heavy objects on the power cord. Never clip, modify, stretch or twist the power cord.



Grasp the plug itself when plug in or unplug the appliance, do not grasp the power cord.



Do not operate the appliance when the power cord is tangle or hang the power cord over the edge of table, counter-top or let it touch any hot surface, it may cause power cord damage.











Do not operate the appliance in the following places:

- Humid environment or near water;
- Expose to sunlight or near heat sources such as electric oven, induction cooker and fire;
- Unstable surface
- Near inflammable or non-resistant to heat objects (e.g. table cloth, curtain and towel etc.)



 **WARNING**

-  Make sure both ends of the power cord are plugged in tightly on the appliance and the power socket before use. Otherwise, it will cause power cord overheat due to contact failure.
-  Do not share the same socket with other high power appliances or use the extension cord beyond its capacity; otherwise it will cause power overload and fire.
-  Make sure the plug is dry before use.
-  Never leave the appliance unattended when in use.
-  Never cover the appliance surface or block the steam vent with any objects, otherwise it may discolor or deform.
-  Always pay attention to the water level. Make sure to refill water before the water level is below the REFILL mark to avoid boil-dry.
-  Do not add water exceed the full water line. Otherwise hot water may spill out during operation and cause burns.
-  Never immerse the appliance, power cord or plug in water or let them wet, it can cause electric shock or fire.



## WARNING



Never allow children to operate, clean, perform maintenance on the appliance alone or play as toy. Please put the appliance and its power cord in a place not reachable by children.



Do not attempt to modify the appliance by yourself or repair with any unauthorized parts, otherwise it will cause hazards and warranty will become invalid.



Do not rotate the appliance while dispensing water, otherwise the hot water may spill out and cause burns.



Do not touch, plug in or remove the plug with wet hands, it can cause electric shock.



Do not use the dispense function or open the lid while boiling, the hot water may spill out or mass steam will come out which can cause burns.



Always check the condition of the appliance, power cord and plug. To avoid hazards, stop using the appliance immediately and contact Shun Hing Electric Service Centre Limited for checking and repairing if any of the parts is damaged.



## WARNING



Do not operate the appliance when it is empty, it is to avoid boil-dry. The inner pot will become yellow, the performance and durability of the appliance will be affected if it is boiled dry frequently.



The appliance is intended to be used in household or similar applications such as staff kitchen area in shops, offices and other working environments; by clients in hotels, motels and other residential type environments.



The appliance can be used by children aged from 8 years and above and persons with reduced physical, sensory or mental capabilities or lack of experience and knowledge, if they have been given supervision or instruction concerning use of the appliance in a safe way and understand the hazards involved.



Mass hot steam comes out from the steam vent during use or right after used. To avoid burns, do not get your face or hands close or touch the lid or steam vent, or touch the hot surfaces e.g. housing. Never touch the heating parts after use which are subject to residual heat.

## 2. Cleaning, Storage and Maintenance

1. Unplug the thermo pot and allow it to cool down completely before cleaning.
2. It is recommended to empty the remnant water in the thermo pot everyday, otherwise water scale may form on the inner pot or cause bad smell. Before pouring out water, ensure to unplug the thermo pot and detach the lid. When pouring out the remnant water, be sure that water does not splash onto the control panel, or get into the appliance, grip the handle and hold the main body firmly, then tilt the main body slowly to pour.
3. Do not wash the thermo pot with water directly. Wipe the main body surface by a damp cloth.
4. Do not use any poisonous or corrosive detergent to clean the thermo pot. If it is too dirty, wipe the main body with a damp cloth soaked with mild detergent, then wipe with a clean damp cloth.
5. Maintenance of the lid

The lid will deteriorate after long time usage, the degree of deterioration varies with the water quality and usage frequency. If the lid is damaged or cracked which hinder the water dispense, please contact Shun Hing Electric Service Centre Ltd. for checking or purchase a new lid for replacement.

6. Maintenance of inner pot

When the thermo pot is in use, you may find some color spots attached on the inner pot surface, which may be in milky white, brown or black. This is the water scale formed by minerals in water. To prevent water scale or color spots, clean the inner pot regularly. Use a soft sponge to clean the inner pot. Do not use cleaning powder or metal brush to avoid damage to the inner pot surface.

To remove the water scale, please follow the below methods:

- Put 1-2 sliced lemon in the inner pot. (Or add about 20g citric acid for every 1 liter water.)
- Fill cool water into the inner pot till the FULL mark.

- Press the **CLEAN** button, the Power on icon and Clean icon will display. The appliance will start to boil water. Then, the Clean icon will change to flash means that cleaning is completed. Pour all the water out after soaking for around 1 hour. Clean the inner pot with a sponge or soft brush, then rinse by water.
- In order to remove the remaining citric acid, you can refill water to boil again and pour out all water afterward.

### 3. Product Specification

Model No	RTP-W50WC
Rated Voltage	220-240 V~ 50/60 Hz
Rated Power	750-890 W
Inner Pot Material	Stainless Steel
Capacity	5.0 L
Net Weight (approx.)	2.1 kg
Product Size (W x D x H)	295 x 235 x 309 mm

## 4. Product Description

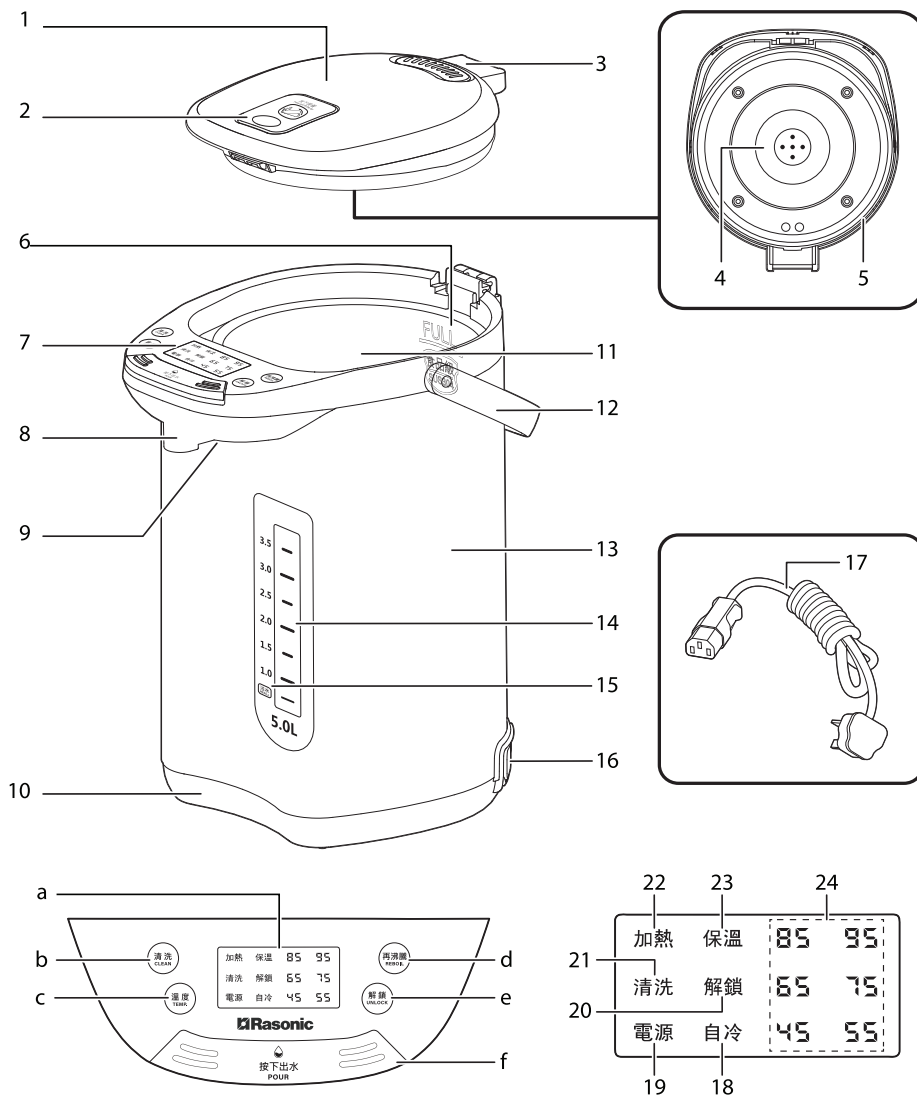

## PARTS

1. Lid
2. Lid opening lever
3. Steam vent
4. Inner lid
5. Sealing ring
6. FULL mark
7. Control panel
  - a. LCD screen
  - b. **CLEAN** button
  - c. **TEMP.** button
  - d. **REBOIL** button
  - e. **UNLOCK** button
  - f. **POUR** button
8. Spout
9. Cup push button
10. Rotating base
11. Water tank
12. Handle
13. Main body
14. Water level gauge
15. REFILL mark
16. Socket
17. Power cord and plug

## LCD SCREEN ICONS

18. Self-cooling mode "自冷"
19. Power on "電源"
20. Unlock "解鎖"
21. Cleaning mode "清洗"
22. Heating mode "加熱"
23. Keep warm mode "保溫"
24. Keep warm temperature settings (°C)

## 5. Operation Instruction

### 5.1 Setup

1. Place the appliance on a stable, non-slip, heat-resistant and waterproof surface.
2. Press and lift the lid opening lever (as shown on the appliance) to open the lid.
3. Fill the water tank with room temperature water. Use a jug of water to fill up the water tank. Ensure the water level is above the REFILL mark and below the FULL mark.
4. Close the lid making sure it is tightly shut.

**NOTE:** If the lid is not correctly closed, the appliance will not heat to the desired temperature.

- Before using the appliance for the first time, fill with water to the FULL mark and boil it. Then discard the water. This will remove any dirt or odours. Wipe the main body with a soft damp cloth.

### 5.2 Turning the appliance on

- Plug the power cord into the socket on the back of the appliance. Insert the plug into the wall socket. A beep will sound and the screen will turn on.
- The appliance will automatically enter the heating mode and keep warm at default temperature 85°C after water boiled.
- When in heating mode, the Power on icon, Heating icon and set temperature will display.
- If the appliance boils dry, it will stop heating. The Heating and Unlock icons will flash to alert you. To unlock and start using the appliance again:
  1. Remove the plug from the wall socket.
  2. Fill the appliance with water ensuring it is above the REFILL mark.
  3. Insert the plug into the wall socket.



## CAUTION:

- Always keep the lid closed during heating.
- Keep your hands and face away from steam released through the steam vent or when opening and closing the lid.

### 5.3 Setting the keep warm temperature / self-cooling mode

- To set a keep warm temperature for when the water has boiled, press the **TEMP.** button repeatedly to select: 95°C, 85°C, 75°C, 65°C, 55°C, 45°C or self-cooling.
- The appliance will start heating and the Keep warm icon displays. When the water has boiled, the keep warm function will turn on. The temperature flashes while the water cools to the keep warm temperature. Once the set temperature has been reached, the temperature will stop flashing.

**NOTE:** There is no time limit for how long the appliance can keep the water warm. As long as it is connected to the power supply, the water will be kept warm.

- If the water temperature drops 5°C below the set keep warm temperature, the Heating icon and temperature will display while the appliance heats up the water to the set temperature.
- If the self-cooling mode is selected, the keep warm mode is deactivated and the Self-cooling icon will display. The water will gradually cool to room temperature.

### 5.4 Using the re-boil mode

- When the water is being kept warm, press the **REBOIL** button to re-boil water.
- The Heating icon will display until the water has boiled.
- Re-boiling water helps to reduce the chlorine in water, making it taste and smell better.

## 5.5 Using the child safety lock

- The appliance equipped with child safety lock which is used to prevent children from accidentally pressing the **POUR** button/ Cup push button and releasing hot water from the appliance. (The lock is activated in standby mode).
- Press the **UNLOCK** button to turn off the child safety lock, the Unlock icon will display representing that the child safety lock is deactivated.

## 5.6 Pouring the water

- To pour the water, make sure the child safety lock is turned off.
- Place a cup or jug under the spout and then press the **POUR** button. Alternatively, press a cup up against the cup push button to start pouring water into a cup. Release the button to stop pouring.
- If the appliance is not being use for a prolonged period of time, empty the water tank and unplug the power cord from the socket.

## 5.7 Removing the lid

1. Open the lid, remove it by pulling in the direction of the spout and then lifting it off.

**NOTE:** You must remove the lid to ensure the lid and the electronic control panel do not get wet when emptying the water tank.

2. Slowly pour out all the water making sure the control panel does not get wet.
3. Use a soft, damp cloth to clean the interior and exterior of the appliance.
4. Dry all parts thoroughly and reinstall the lid.

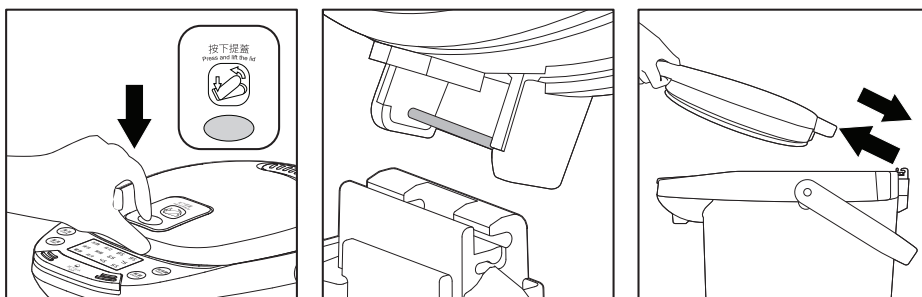

## 6. Trouble Shooting

Trouble	Causes	Treatment
Water has white or shiny particles.	Water scale of inner pot peeled off.	Please follow the instructions on page 18 of "Maintenance of inner pot" to remove the water scale.
Smell comes from the water.	<ul style="list-style-type: none"> <li>• Tap water contains chlorine smell.</li> <li>• The smell comes from the sealed packing at the beginning.</li> </ul>	<ul style="list-style-type: none"> <li>• Press <b>REBOIL</b> button to eliminate the chlorine smell.</li> <li>• The smell will disappear with time. Boiling water with lemon or citric acid can eliminate the smell.</li> </ul>
Water dispense is not smooth.	The water filter is blocked.	Clean the filter with a soft brush.
Water dispenses automatically.	Water is filled above the full water level.	Pour water out until water is below the full water level.
The thermo pot cannot boil water.	The plug is not connected securely.	Check and re-connect the plug.

If the above solutions cannot fix the problem, please contact Shun Hing Electric Service Centre Ltd. to check and repair.

## 7. Special Avowal

1. The content in the operation manual has been checked. Our company reserves the hermeneutic power to any printing errors or misunderstanding on the content.

2. If there are technical improvements on the appliance, the operation manual will be updated in new version without prior notice. The product appearance and specification are subject to the manufacturer information.
3. The e-copy of user manual can be sent by e-mail on requested. For enquires, please call Shun Hing Electric Works & Engineering Co, Ltd hotline at 2861 2767.

## **8. After Sales Service**

Shun Hing Electric Works & Engineering Co., Ltd. ("The Company") authorizes Shun Hing Electric Service Centre Ltd. ("SHESC") (collectively "Shun Hing") to offer one year warranty service to the product commencing from the date of purchase invoice. Services beyond the said warranty period will be charges according to the standard service charge price list from SHESC.

1. Shun Hing shall not be liable for any direct or indirect loss or damage to any person or property, howsoever caused arising from improper use, or any stoppage, breakdown or failure of the product.
2. Customer is responsible to deliver the product to our service station or any place in urban area, and to pick up the repaired product from the same location.
3. The warranty card (printed on the packing box) is valid only in Hong Kong and Macau. Customer is required to present the warranty card together with the official purchase invoice issued by the dealers of Hong Kong or Macau or redemption voucher to our technician for verification when service is rendered. The warranty card is valid only if the model number stated herein corresponds with that of the product and the date of purchase stated herein is the same with the date of official purchase invoice. Save and except the specific warranty card, any other warranty card issued by other parties will not be recognized by Shun Hing.
4. Customer shall not alter the serial number of the product. The warranty card is void if the serial number on the product does not match with that shown on the warranty card (if applicable).
5. For any defect which in our judgment is caused under normal use, SHESC will repair or replace the defective parts, excluding any surface, cabinet, consumptive parts and accessories, free of charge within the warranty period. Any defective part which has been replaced shall become the property of SHESC.

6. Warranty service does not cover the following items. Additional charges shall be levied if services are required. (a) Repair or replacement of accessories, external cables or cabinet of the product. (b) The product has been explicitly or implicitly modified, tempered with, altered or repaired in any way by persons other than technicians of SHESC. (c) The product has been damaged through misuse, negligence, power interruption or abnormal voltage input, accident, natural calamities, or due to ingress of insects, foreign matters or liquid, corrosion or external factors. (d) The normal operation of the product is affected by improper installation of the product.
7. In case there is any inconsistency or conflict between English version and Chinese version of the terms, the Chinese version shall prevail.
8. All terms stated are subject to change without notice. SHESC retains final deciding authority in case of dispute.
9. Nothing in the warranty card confers or purports to confer on any third party any benefit or any right pursuant to the Contracts (Rights of Third Parties) Ordinance (Cap. 623) to enforce any term of the warranty card.

## 信興電工工程有限公司

**SHUN HING ELECTRIC WORKS AND ENGINEERING CO., LTD.**

辦公室：香港九龍尖沙咀東部麼地道67號半島中心9樓909-912室

電話：2861 2767

圖文傳真：2865 6706

網址：<http://www.rasonic.com>

電郵：[shew@shunhinggroup.com](mailto:shew@shunhinggroup.com)

Office: Room 909-912,9/F., Peninsula Centre, 67 Mody Road, Tsimshatsui East, Kowloon, H.K.

Tel: 2861 2767

Fax: 2865 6706

Website: <http://www.rasonic.com>

E-mail: [shew@shunhinggroup.com](mailto:shew@shunhinggroup.com)

保養及維修 Maintenance and Repair Service:

## 信興電器服務中心有限公司

**SHUN HING ELECTRIC SERVICE CENTRE LTD.**

香港新界葵涌勝耀街2號信興中心11樓

服務熱線：2406 5666

傳真號碼：2408 0316

網址：<http://www.shesc.com/zh>

11/F, Shun Hing Centre, 2 Shing Yiu Street, Kwai Chung, N.T., H.K.

Service Hotline: 2406 5666

Fax No.: 2408 0316

Website: <http://www.shesc.com/en>

客戶服務中心：

香港新界葵涌勝耀街 2 號信興中心 1 樓

九龍尖沙咀東部麼地道 67 號半島中心B座 9 樓

香港天后琉璃街 7 號柏景中心 22 樓

澳門慕拉士大馬路193-199 號南嶺工業大廈 5 樓 I 座

有關最新之香港及澳門客戶服務中心資料，請參閱信興服務中心網址：[www.shesc.com](http://www.shesc.com)。

Customer Service Centres:

1/F, Shun Hing Centre, 2 Shing Yiu Street, Kwai Chung, N.T., H.K.

9/F, Block B, Peninsula Centre, 67 Mody Road, Tsim Sha Tsui, Kowloon

22/F, Parkview Centre, 7 Lau Li Street, Tin Hau, H.K.

Avenida de Venceslau de Morais, No.193-199, 5 andar - I, Edf. Industrial Nam Leng, Macau

For the latest information of Hong Kong and Macau service center, please visit [www.shesc.com](http://www.shesc.com).